

 **SOCOMEK**

KS



Foto della macchina conforme alle norme CE •
Abgebildetes Modell in EG-Ausführung •
Picture of the machine in CE version •
Photo de la machine conforme aux normes CE •
Foto de la maquina conforme normas CE •

**LEVIGATRICE PER BORDI
KANTENSCHLEIFMASCHINE
EDGE SANDING MACHINE
PONCEUSE DE CHANTS
LIJADORA DE CONTORNOS**

DATI TECNICI		KS
Motore trifase HP/KW	2 (1,5)	
Velocità nastro m/sec	15	
Lunghezza utile di lavoro mm	850	
Larghezza nastro mm	150	
Sviluppo nastro mm	2250	
Dimensioni piano nastro mm	650x220	
Inclinazione nastro	0÷90°	
Peso netto Kg	100	

TECHNISCHE DATEN		KS
E - Motor 380 V PS/KW	2 (1,5)	
Bandgeschwindigkeit m/Sek	15	
Arbeitslänge mm	850	
Bandbreite mm	150	
Bandlänge mm	2250	
Abmessungen des Bandtisches mm	650x220	
Schleiteinheit Schwenkbar	0÷90°	
Gewicht Kg	100	

TECHNICAL DATA		KS
Threephase motor HP/KW	2 (1,5)	
Belt speed m/sec	15	
Working length mm	850	
Width of the belt mm	150	
Length of the belt mm	2250	
Dimensions of the belt's table mm	650x220	
Blade tilting	0÷90°	
Net weight Kg	100	

DONNÉES TECHNIQUES		KS
Moteur triphase CV/KW	2 (1,5)	
Vitesse de la bande m/sec	15	
Longueur de travail mm	850	
Largeur de la bande mm	150	
Longueur de la bande mm	2250	
Dimensions table de la bande mm	650x220	
Inclinaison du ruban	0÷90°	
Poids net Kg	100	

DATOS TECNICOS		KS
Motor trifásico HP/KW	2 (1,5)	
Velocidad de la bande m/seg	15	
Longitud. mesa de trabajo mm	850	
Anchura banda lijado mm	150	
Longitud. banda lijado mm	2250	
Inclinación de la banda	0÷90°	
Peso neto Kg	100	

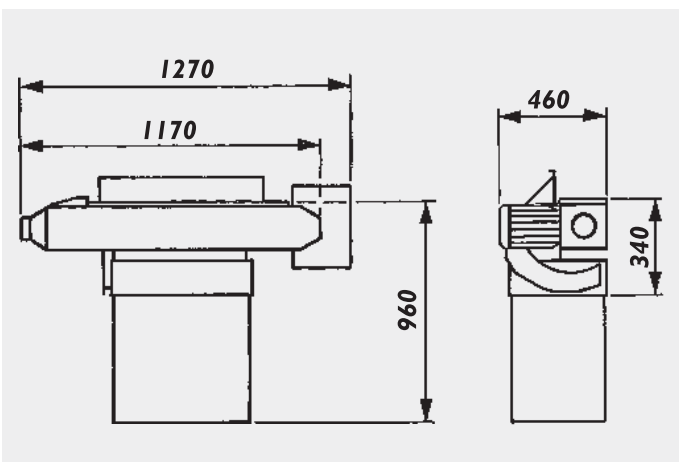

- Base
- Untergestell
- Base
- Socle
- Pedestal

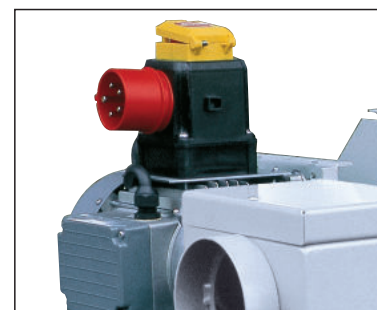

- Impianto elettrico a norme CE
- Elektrische Anlage nach CE - Vorschrift
- Electric installation according to CE
- Installation électrique selon normes CE
- Instalación eléctrica según reglas CE

• A RICHIESTA • ZUBEHÖR • OPTIONALS • • OPTIONS • PRINCIPALES OPCIONALES •

- Piano per levigare pezzi sagomati al rullo con cappa di aspirazione (Dimensioni piano posteriore mm. 350x250)
- Tisch zum Schleifen runder Innenkanten an der Rolle mit Absaughaube (Zusatztischgröße mm. 350x250)
- Table for round sanding at the roller with suction hood (Additional table dim. mm. 350x250)
- Table pour le ponçage au rouleau des pièces courbes avec capot d'aspiration (Dimensions table adjointe mm. 350x250)
- Mesa para lijar a rodillo con capa de aspiración (Medidas mesa adjunta mm. 350x250)

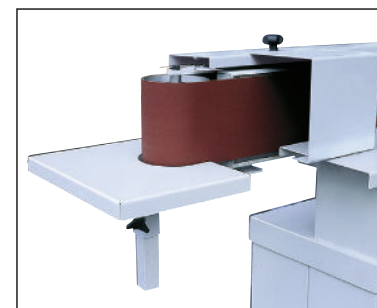

- Squadretto per levigature angolate
- Winkelschleifanschlag
- Little fence for angled sanding working
- Equerre pour polissages anguleuses
- Escuadra para hacer lijaduras angulares

